



# Subnetting IP Networks



Cisco | Networking Academy®  
Mind Wide Open™



# Chapter 9

- 9.0 Introduction
- 9.1 Subnetting an IPv4 Network
- 9.2 Addressing Schemes
- 9.3 Design Considerations for IPv6



# Chapter 9: Objectives

Upon completion of this chapter, you will be able to:

- Explain why routing is necessary for hosts on different networks to communicate.
- Describe IP as a communication protocol used to identify a single device on a network.
- Given a network and a subnet mask, calculate the number of host addresses available.
- Calculate the necessary subnet mask in order to accommodate the requirements of a network.
- Describe the benefits of variable length subnet masking (VLSM).
- Explain how IPv6 address assignments are implemented in a business network.



## 9.1 Subnetting an IPv4 Network



Cisco | Networking Academy®  
Mind Wide Open™



## Network Segmentation

# Reasons for Subnetting

**Subnetting** is the process of segmenting a network into multiple smaller network spaces called subnetworks or subnets.

- Large networks must be segmented into smaller subnetworks, creating smaller groups of devices and services to:
  - Control traffic by containing broadcast traffic within each subnetwork.
  - Reduce overall network traffic and improve network performance.

## Communication Between Subnets

- A router is necessary for devices on different networks and subnets to communicate.
- Each router interface must have an IPv4 host address that belongs to the network or subnet that the router interface is connected.
- Devices on a network and subnet use the router interface attached to their LAN as their default gateway.



# IP Subnetting is FUNdamental

## The Plan

### Planning the Network

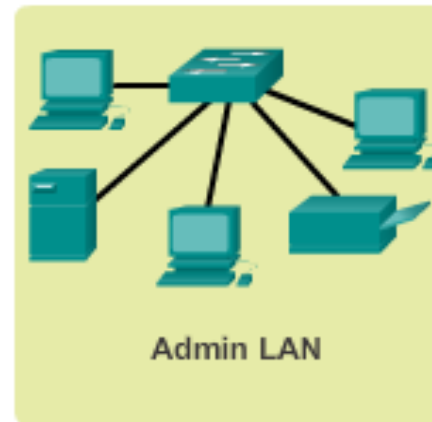
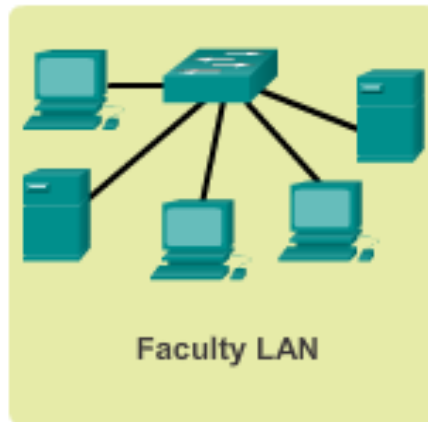
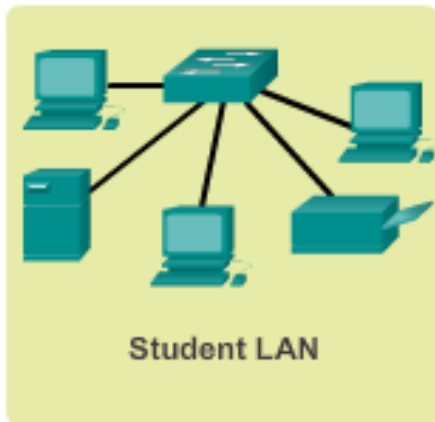

Planning requires decisions on each subnet in terms of size, the number of hosts per subnet, and how host addresses will be assigned.



# Subnetting an IPv4 Network

## Basic Subnetting

- Borrowing Bits to Create Subnets
- Borrowing 1 bit  $2^1 = 2$  subnets

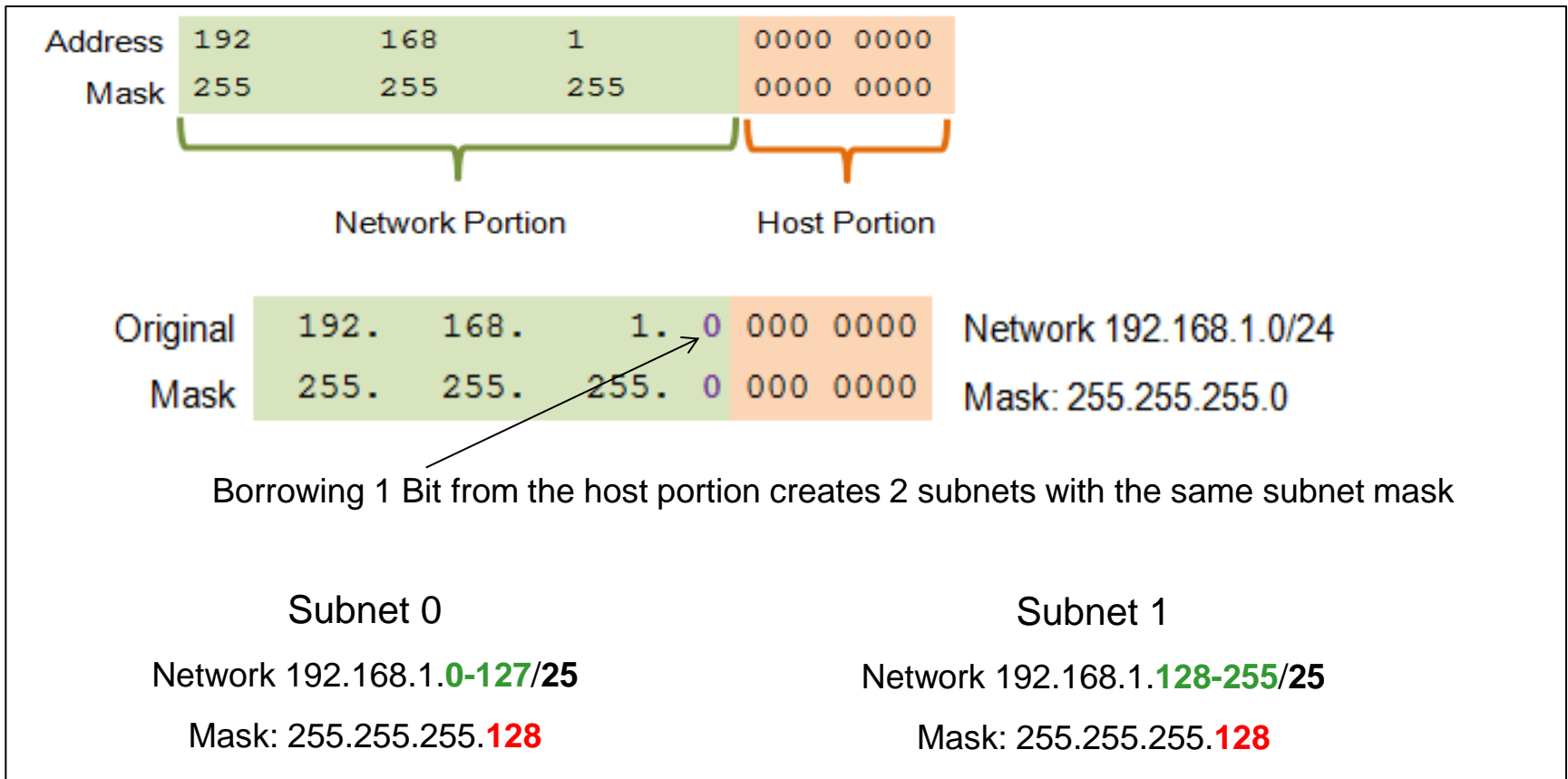



# Subnetting an IPv4 Network

## Subnets in Use

### Subnets in Use

Subnet 0

Network 192.168.1.0-127/25

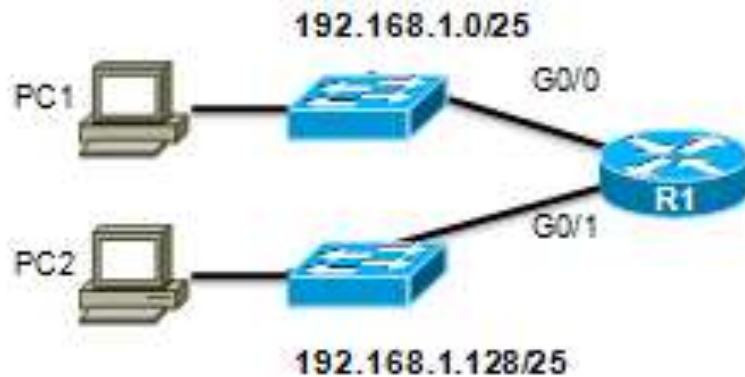

Subnet 1

Network 192.168.1.128-255/25

#### Address Range for 192.168.1.0/25 Subnet

Network Address

192. 168. 1. 0 000 0000 = 192.168.1.0

First Host Address

192. 168. 1. 0 000 0001 = 192.168.1.1

Last Host Address

192. 168. 1. 0 111 1110 = 192.168.1.126

Broadcast Address

192. 168. 1. 0 111 1111 = 192.168.1.127

#### Address Range for 192.168.1.128/25 Subnet

Network Address

192. 168. 1. 1 000 0000 = 192.168.1.128

First Host Address

192. 168. 1. 1 000 0001 = 192.168.1.129

Last Host Address

192. 168. 1. 1 111 1110 = 192.168.1.254

Broadcast Address

192. 168. 1. 1 111 1111 = 192.168.1.255





# Subnetting an IPv4 Network

## Subnetting Formulas

### Calculate number of subnets

Subnets =  $2^n$   
 (where n = bits borrowed)

192. 168. 1. 0 000 0000

↑  
 1 bit was borrowed

$2^1 = 2$  subnets

### Calculate number of hosts

Hosts =  $2^n$   
 (where n = host bits remaining)

192. 168. 1. 0 000 0000

↑  
 7 bits remain in host field

$2^7 = 128$  addresses per subnet  
 $2^7 - 2 = 126$  valid hosts per subnet



# Subnetting an IPv4 Network

## Creating 4 Subnets

Borrowing 2 bits to create 4 subnets.  $2^2 = 4$  subnets

### Creating 4 Subnets

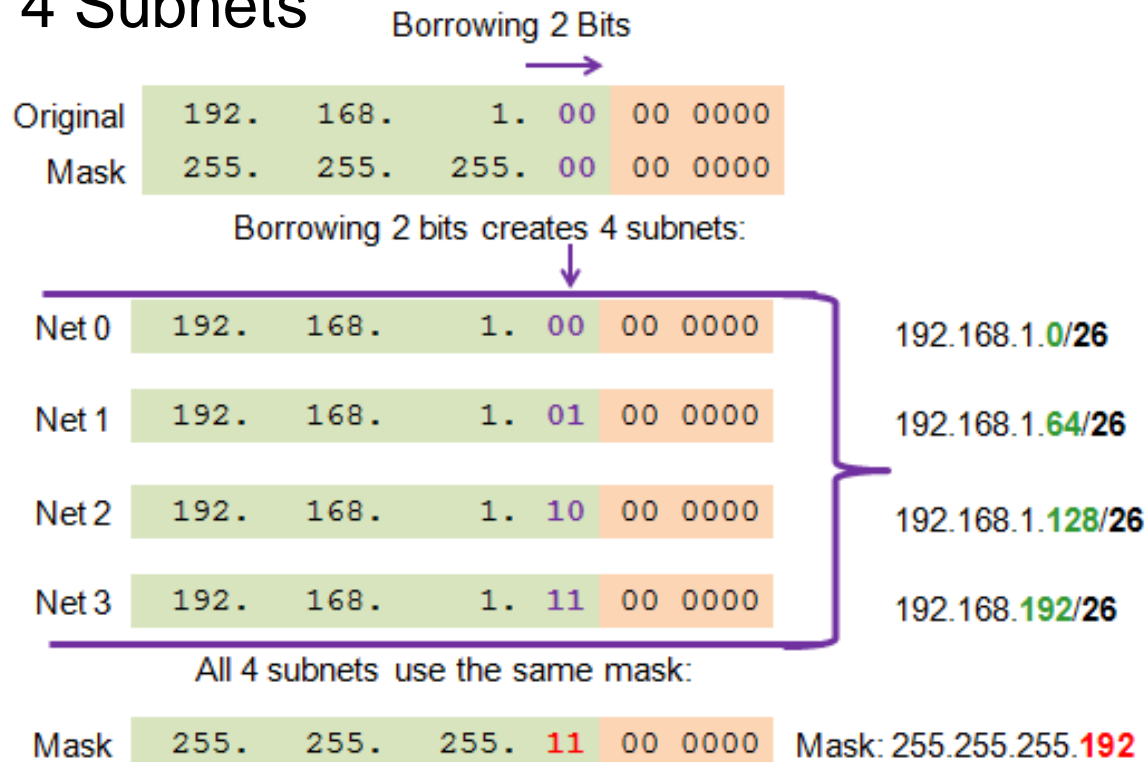



# Subnetting an IPv4 Network

## Creating Eight Subnets

Borrowing 3 bits to **Create 8 Subnets**.  $2^3 = 8$  subnets

Net 0	Network	192.	168.	1.	000	0 0000	192.168.1.0
	First	192.	168.	1.	000	0 0001	192.168.1.1
	Last	192.	168.	1.	000	1 1110	192.168.1.30
	Broadcast	192.	168.	1.	000	1 1111	192.168.1.31
Net 1	Network	192.	168.	1.	001	0 0000	192.168.1.32
	First	192.	168.	1.	001	0 0001	192.168.1.33
	Last	192.	168.	1.	001	1 1110	192.168.1.62
	Broadcast	192.	168.	1.	001	1 1111	192.168.1.63
Net 2	Network	192.	168.	1.	010	0 0000	192.168.1.64
	First	192.	168.	1.	010	0 0001	192.168.1.65
	Last	192.	168.	1.	010	1 1110	192.168.1.94
	Broadcast	192.	168.	1.	010	1 1111	192.168.1.95
Net 3	Network	192.	168.	1.	010	0 0000	192.168.1.96
	First	192.	168.	1.	010	0 0001	192.168.1.97
	Last	192.	168.	1.	010	1 1110	192.168.1.126
	Broadcast	192.	168.	1.	010	1 1111	192.168.1.127



# Subnetting an IPv4 Network

## Creating Eight Subnets (Cont.)

Net 4	Network	192.	168.	1.	100	0 0000	192.168.1.128
	Fist	192.	168.	1.	100	0 0001	192.168.1.129
	Last	192.	168.	1.	100	1 1110	192.168.1.158
	Broadcast	192.	168.	1.	100	1 1111	192.168.1.159
Net 5	Network	192.	168.	1.	101	0 0000	192.168.1.160
	Fist	192.	168.	1.	101	0 0001	192.168.1.161
	Last	192.	168.	1.	101	1 1110	192.168.1.190
	Broadcast	192.	168.	1.	101	1 1111	192.168.1.191
Net 6	Network	192.	168.	1.	110	0 0000	192.168.1.192
	Fist	192.	168.	1.	110	0 0001	192.168.1.193
	Last	192.	168.	1.	110	1 1110	192.168.1.222
	Broadcast	192.	168.	1.	110	1 1111	192.168.1.223
Net 7	Network	192.	168.	1.	111	0 0000	192.168.1.224
	Fist	192.	168.	1.	111	0 0001	192.168.1.225
	Last	192.	168.	1.	111	1 1110	192.168.1.254
	Broadcast	192.	168.	1.	111	1 1111	192.168.1.255

# Subnetting an IPv4 Network

## Creating Eight Subnets (Cont.)

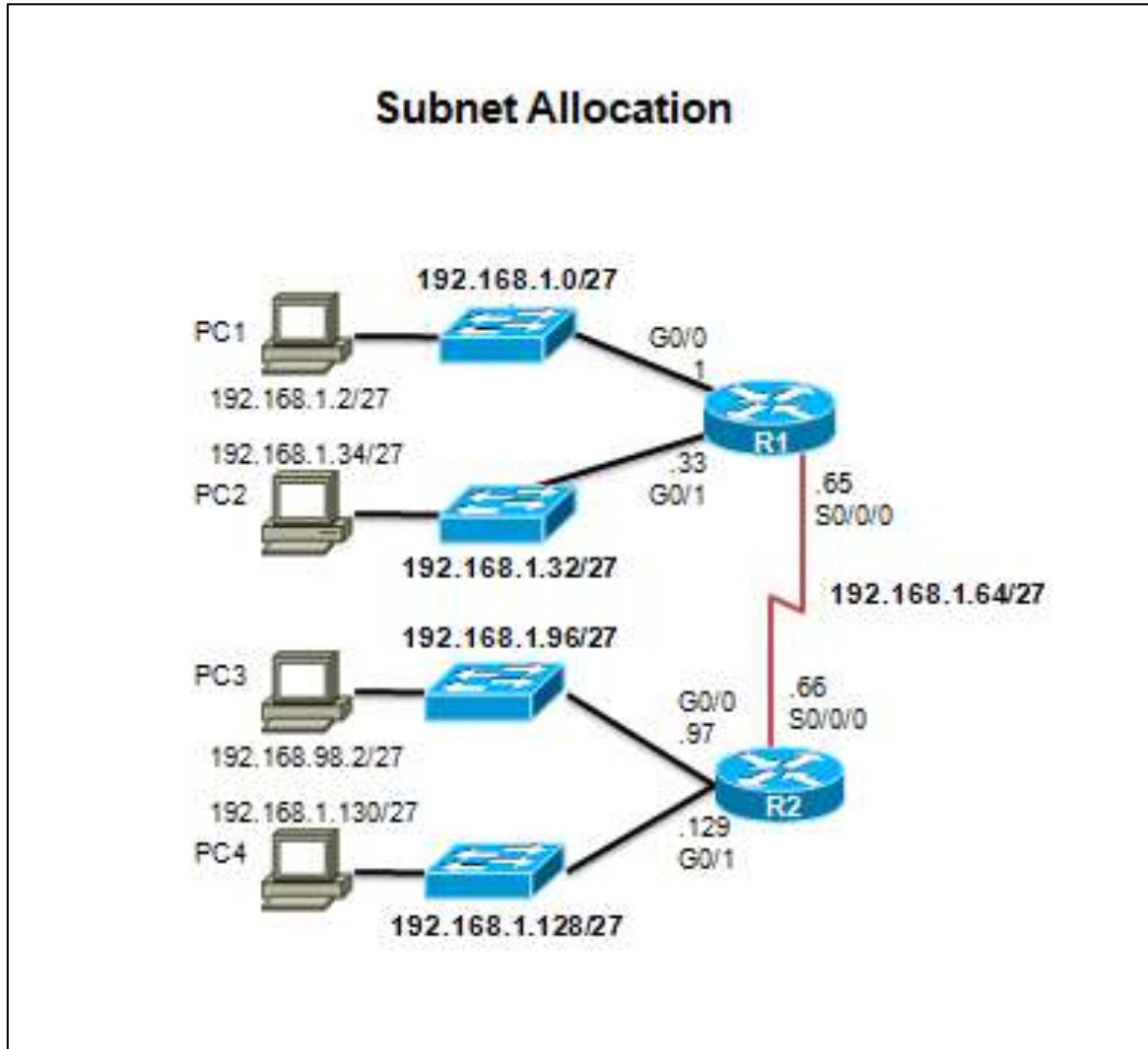



## Determining the Subnet Mask

# Subnetting Based on Host Requirements

### Two considerations when planning subnets:

- Number of subnets required
- Number of host addresses required

### Formula to determine number of usable hosts: $2^n - 2$

- $2^n$  (where  $n$  is the number of remaining host bits) is used to calculate the number of hosts.
- $-2$  (The subnetwork ID and broadcast address cannot be used on each subnet.)



# Determining the Subnet Mask

## Subnetting Network-Based Requirements

### Calculate the number of subnets:

- $2^n$  (where n is the number of bits borrowed)
- Subnet needed for each department.

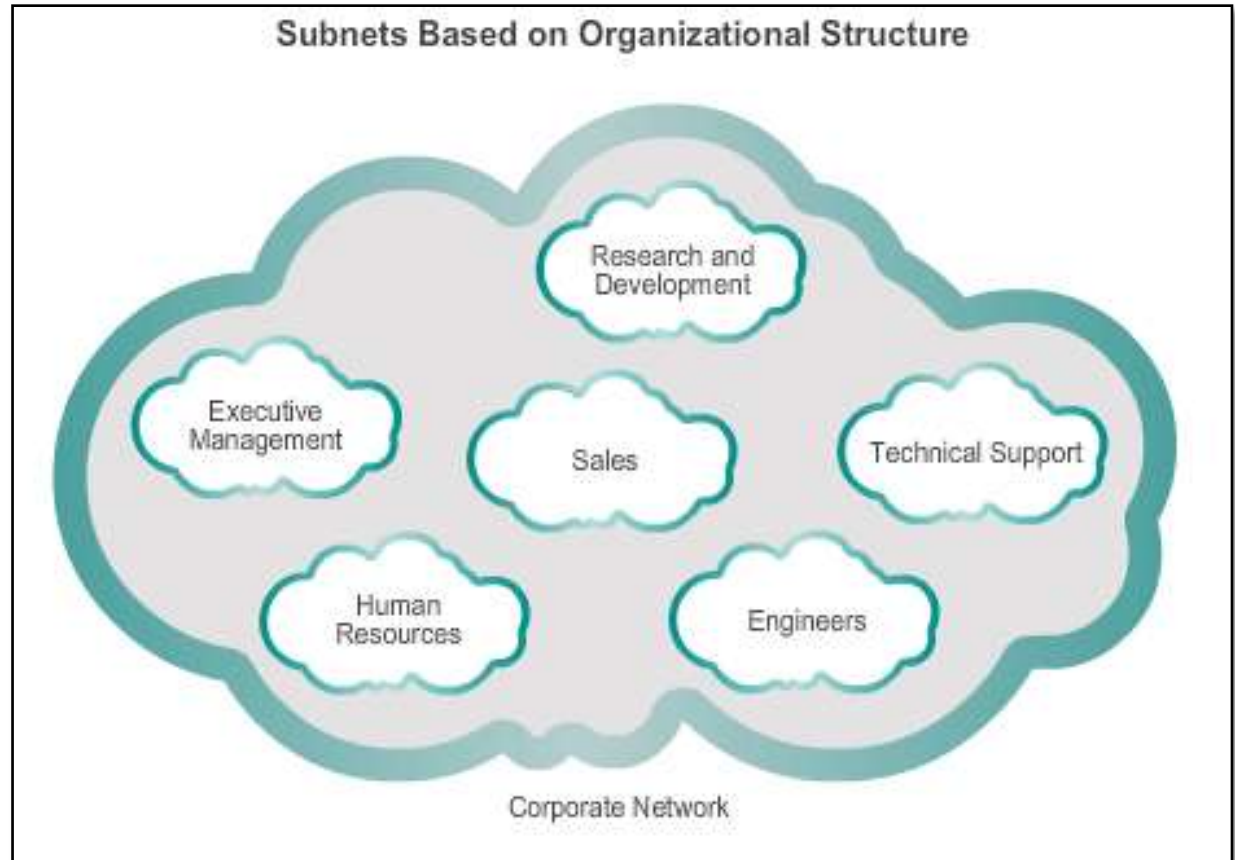





## Determining the Subnet Mask

# Subnetting To Meet Network Requirements

- Balance the required number of subnets and hosts for the largest subnet.
- Design the addressing scheme to accommodate the maximum number of hosts for each subnet.
- Allow for growth in each subnet.

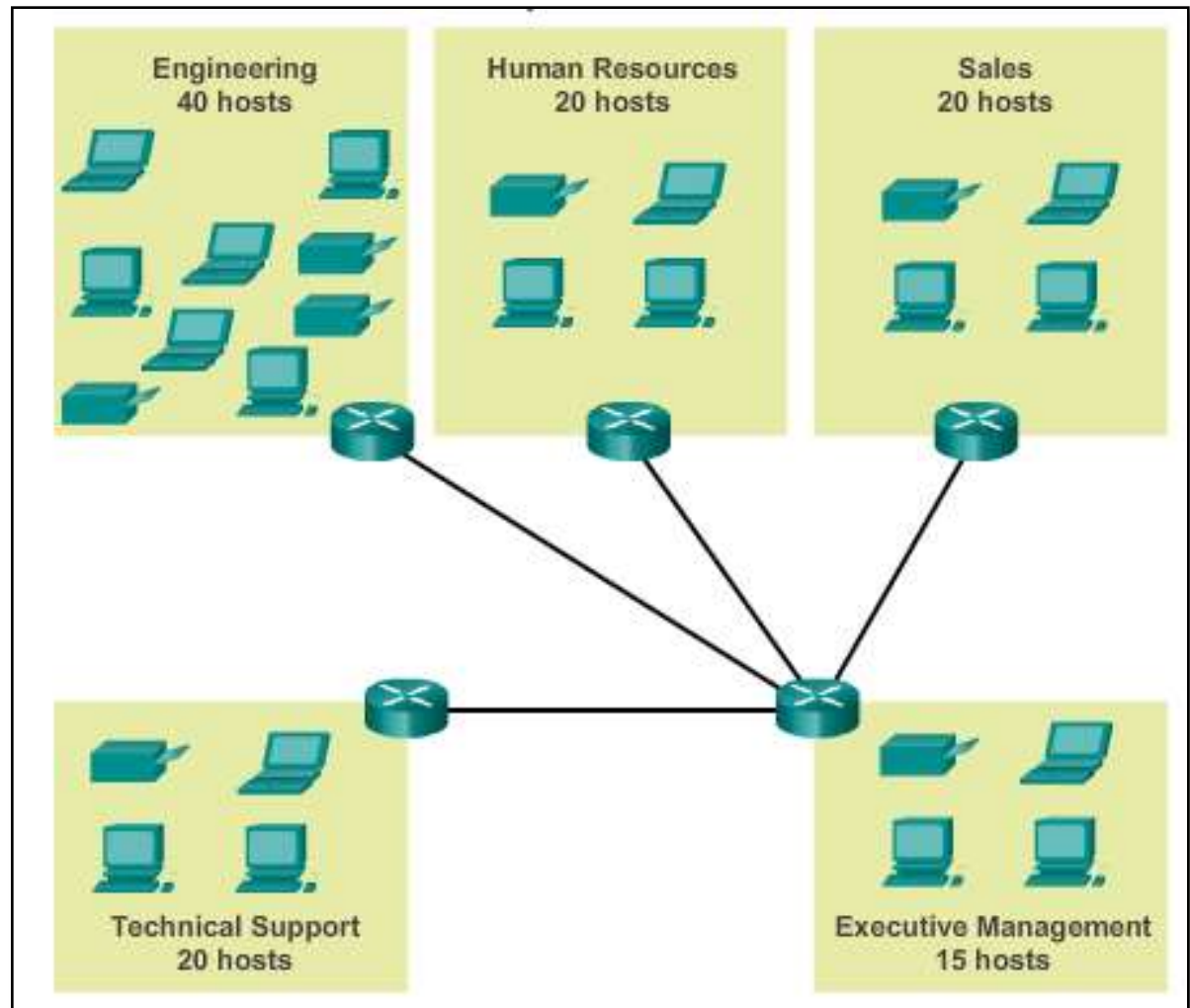





## Determining the Subnet Mask

# Subnetting To Meet Network Requirements

### Subnets and Addresses

	10101100.00010000.00000000.00000000	172.16.0.0/22
0	10101100.00010000.00000000.00000000	172.16.0.0/26
1	10101100.00010000.00000000.00000001	172.16.0.64/26
2	10101100.00010000.00000000.00000010	172.16.0.128/26
3	10101100.00010000.00000000.00000011	172.16.0.192/26
4	10101100.00010000.00000001.00000000	172.16.1.0/26
5	10101100.00010000.00000001.00000001	172.16.1.64/26
6	10101100.00010000.00000001.00000010	172.16.1.128/26

### Nets 7 – 14 not shown

15	10101100.00010000.00000011.00000000	172.16.3.128/26
16	10101100.00010000.00000011.00000001	172.16.3.192/26



  
 $2^4 = 16$  subnets       $2^6 - 2 = 62$  Hosts per subnet



## Benefits of Variable Length Subnet Masking

# Traditional Subnetting Wastes Addresses

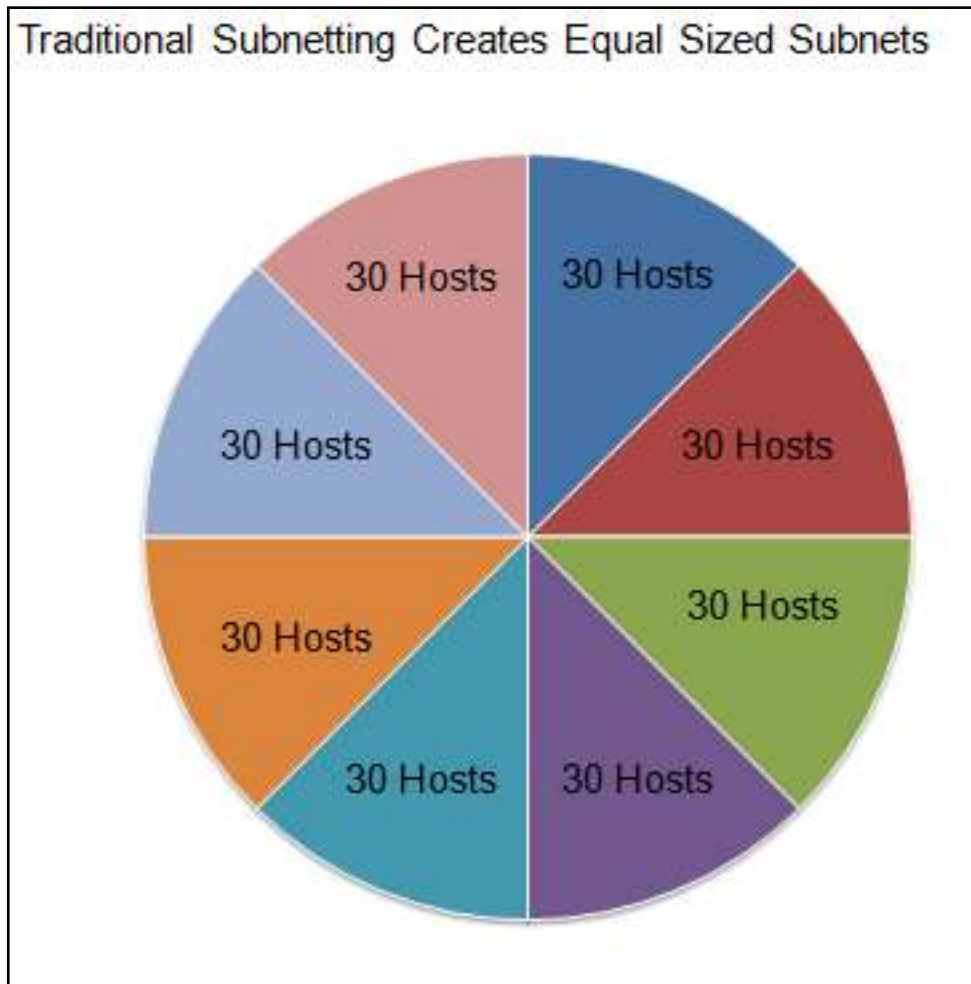
- Traditional subnetting – Uses the same number of addresses is allocated for each subnet.
- Subnets that require fewer addresses have unused (wasted) addresses; for example, WAN links only need two addresses.





## Benefits of Variable Length Subnet Masking

# Variable Length Subnet Masks (VLSM)

- The variable-length subnet mask (VLSM) or subnetting a subnet provides more efficient use of addresses.
- VLSM allows a network space to be divided in unequal parts.
- Subnet mask varies, depending on how many bits have been borrowed for a particular subnet.
- Network is first subnetted, and then the subnets are resubnetted.

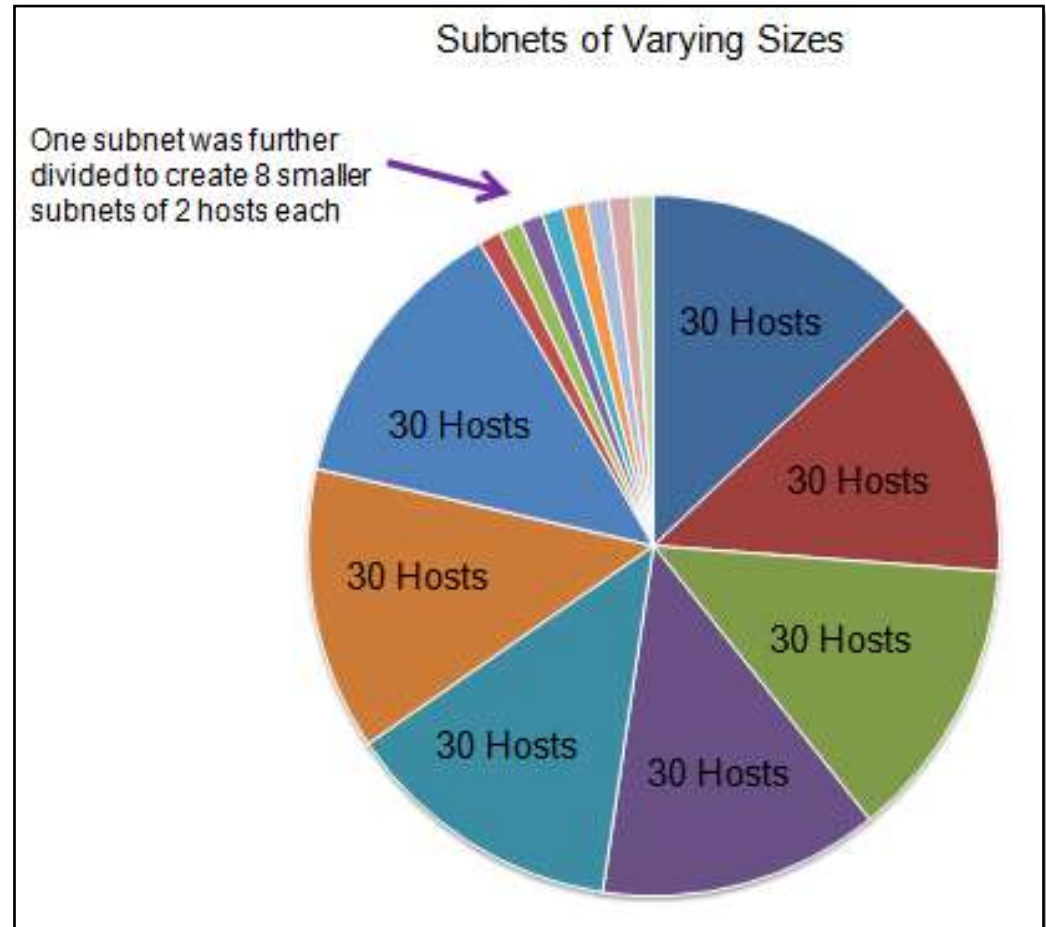



# Benefits of Variable Length Subnet Masking

## Basic VLSM

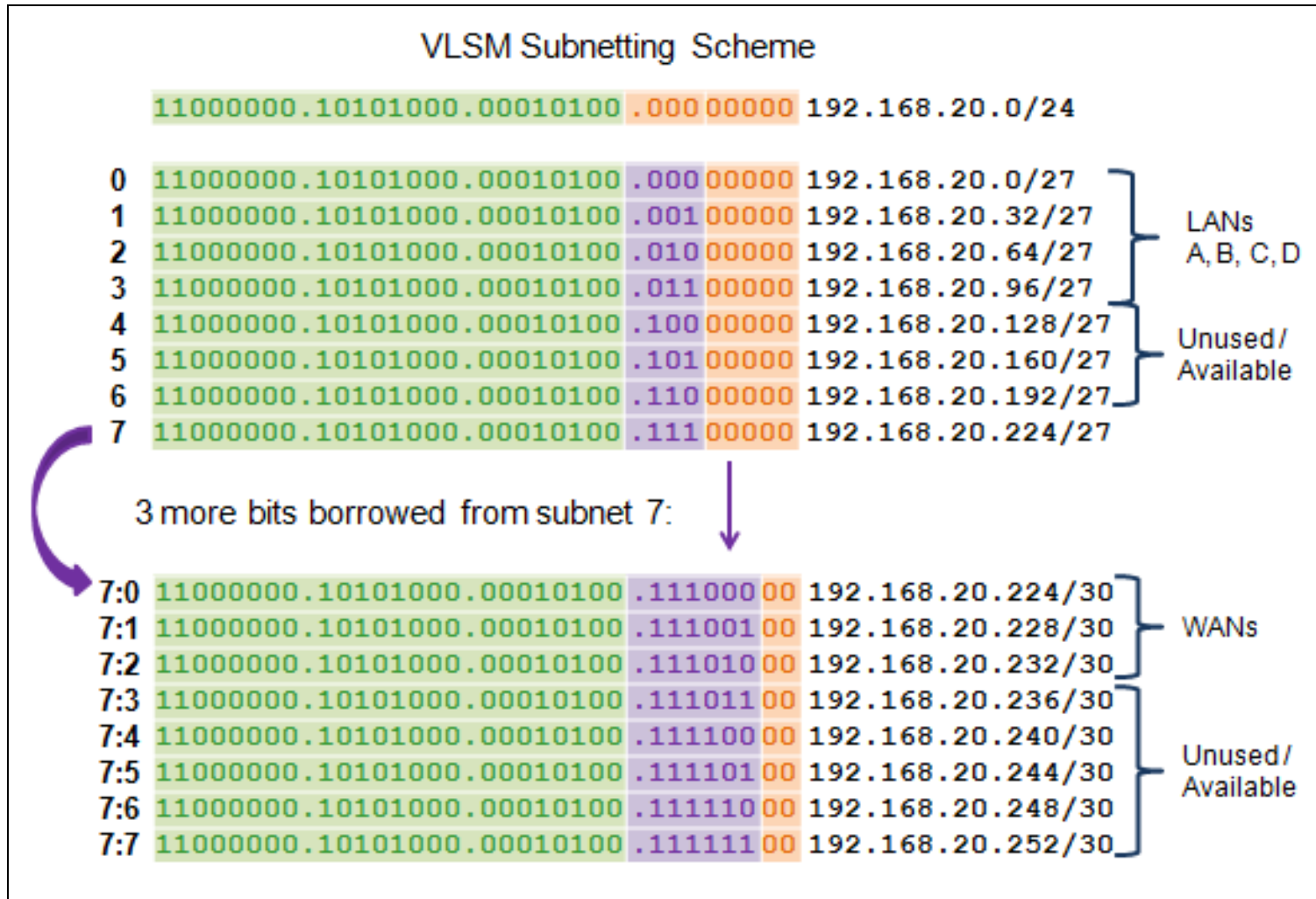



# Benefits of Variable Length Subnet Masking VLSM in Practice

- Using VLSM subnets, the LAN and WAN segments in example below can be addressed with minimum waste.
- Each LANs will be assigned a subnet with /27 mask.
- Each WAN link will be assigned a subnet with /30 mask.

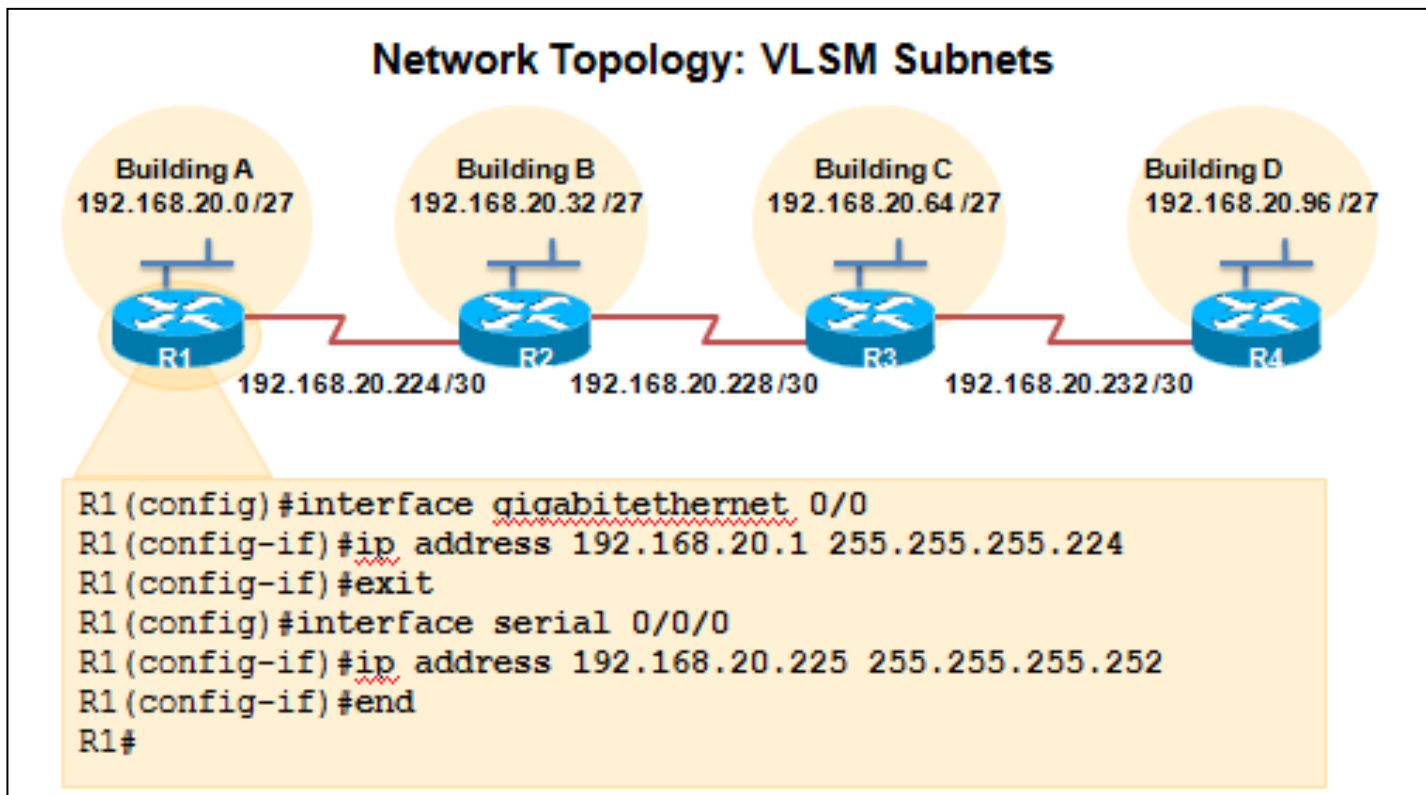



# Benefits of Variable Length Subnet Masking

## VLSM Chart

**VLSM Subnetting of 192.168.20.0 /24**

	/27 Network	Hosts
<u>Bldg A</u>	.0	.1 - .30
<u>Bldg B</u>	.32	.33 - .62
<u>Bldg C</u>	.64	.65 - .94
<u>Bldg D</u>	.96	.97 - .126
Unused	.128	.129 - .158
Unused	.160	.161 - .190
Unused	.192	.193 - .222
	.224	.225 - .254

	/30 Network	Hosts
WAN R1-R2	.224	.225 - .226
WAN R2-R3	.228	.229 - .230
WAN R3-R4	.232	.233 - .234
Unused	.236	.237 - .238
Unused	.240	.241 - .242
Unused	.244	.245 - .246
Unused	.248	.249 - .250
Unused	.252	.253 - .254



## 9.2 Addressing Schemes





# Structured Design

## Planning to Address the Network

Allocation of network addresses should be planned and documented for the purposes of:

- Preventing duplication of addresses
- Providing and controlling access
- Monitoring security and performance

Client addresses – Usually dynamically assigned using the Dynamic Host Configuration Protocol (DHCP).

Sample  
Network  
Addressing  
Plan

Network: 192.168.1.0/24		
Use	First	Last
Host Devices	.1	.229
Servers	.230	.239
Printers	.240	.249
Intermediary Devices	.250	.253
Gateway (router LAN interface)	.254	





## 9.3 Design Considerations for IPv6



Cisco | Networking Academy®  
Mind Wide Open™



# Subnetting an IPv6 Network

## Subnetting Using the Subnet ID

An IPv6 Network Space is subnetted to support hierarchical, logical design of the network

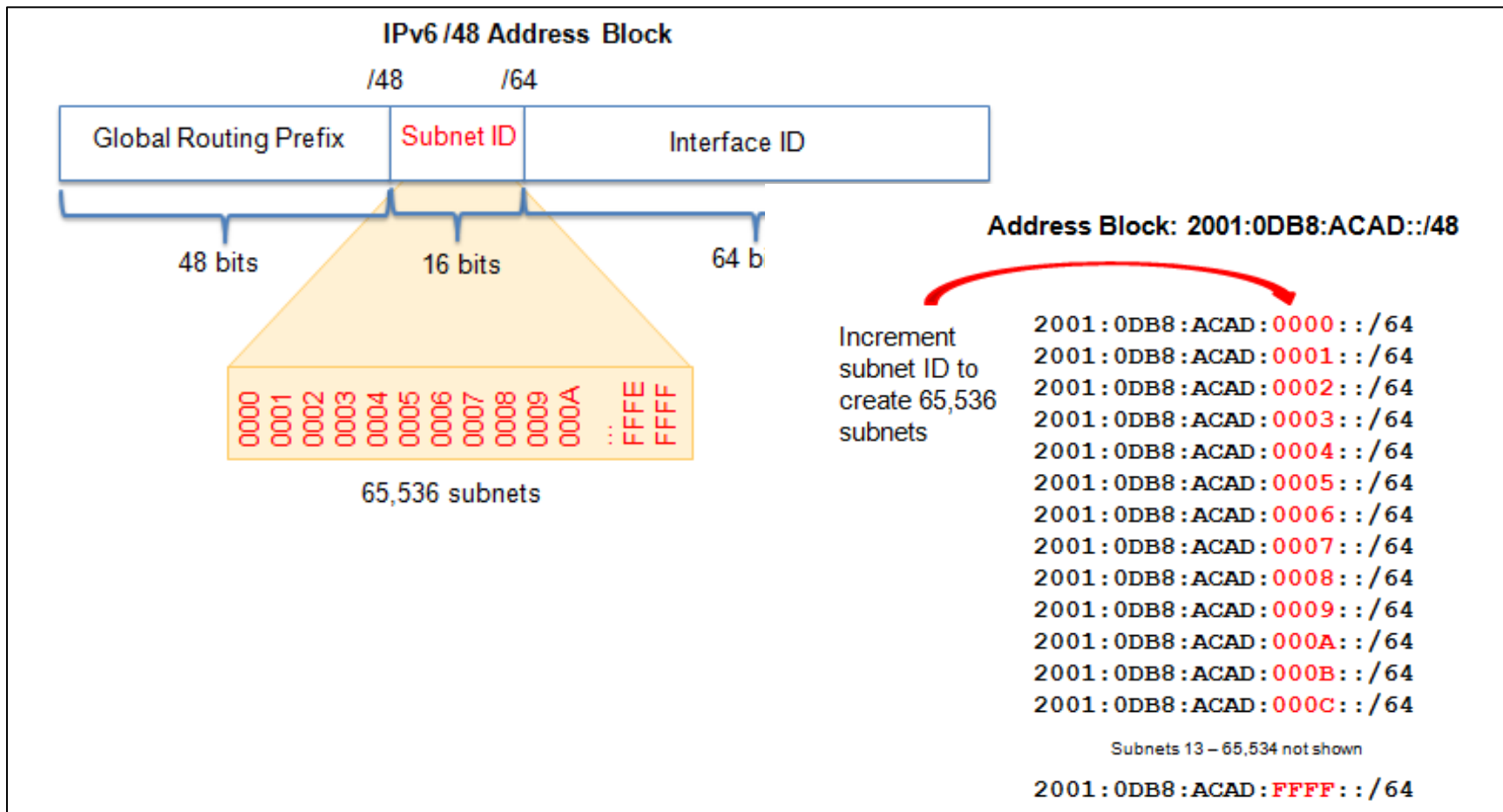

# Subnetting an IPv6 Network

## IPv6 Subnet Allocation

### IPv6 Subnetting

Address Block: 2001:0DB8:ACAD::/48

5 subnets allocated from 65,536 available subnets

- 2001:0DB8:ACAD:0000::/64
- 2001:0DB8:ACAD:0001::/64
- 2001:0DB8:ACAD:0002::/64
- 2001:0DB8:ACAD:0003::/64
- 2001:0DB8:ACAD:0004::/64
- 2001:0DB8:ACAD:0005::/64
- 2001:0DB8:ACAD:0006::/64
- 2001:0DB8:ACAD:0007::/64
- 2001:0DB8:ACAD:0008::/64
- ⋮
- 2001:0DB8:ACAD:FFFF::/64

### IPv6 Subnet Allocation

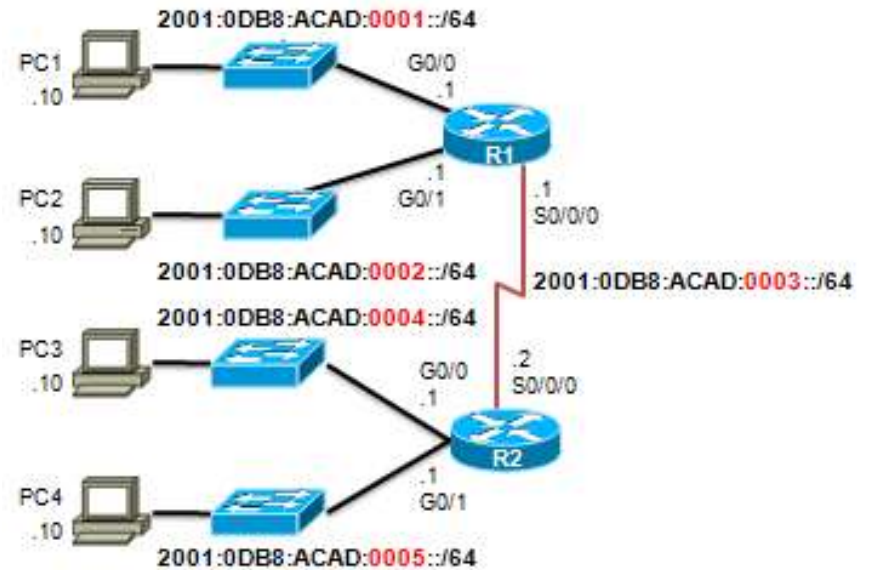



# Subnetting an IPv6 Network

## Subnetting into the Interface ID

IPv6 bits can be borrowed from the interface ID to create additional IPv6 subnets.

